

Serial Converter

SLC22232

February 22, 2006





The Microbotics serial converter is a two channel, full duplex serial line level converter that supports connections to RS-232, RS-422, and TTL devices.

Features

- Small size allows placement inline with wiring harness (30.5 x 12.7 mm, 1.2 x 0.5 in)



- Wide supply range, 4 to 40VDC
- On board mid-level voltage reference to support TTL <=> RS-232 conversion.

Technical

A magnified view of the top of the converter is shown below. Some of the labels on the silkscreen of the actual board may be difficult to read because of their small size, or obscured by installed components.

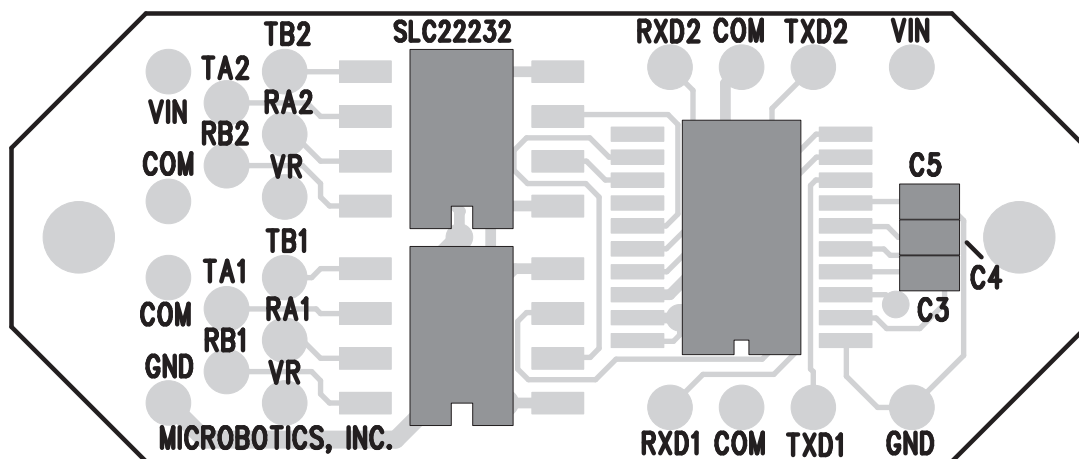

Each of the pads above (small, grey circles) represents an electrical connection on the board. The label next to the pad indicate the signal it connects. The left side of the board is for RS-422 connections. The right side is for RS-232/TTL connections.

Note that all VIN pads are connected on the board, and all GND pads are connected on the board to allow power to be supplied from any connected device and to allow passthrough of power to connected devices. The COM pads are signal grounds.



The labels on the silkscreen correspond to signals as defined in the following table.

Lettering	Description
RXD1	RS-232 receiver for channel 1
TXD1	RS-232 transmitter for channel 1
RXD2	RS-232 receiver for channel 2
TXD2	RS-232 transmitter for channel 2
TB1	RS-422 output for channel 1
TA1	RS-422 inverted output for channel 1
RB1	RS-422 input for channel 1
RA1	RS-422 inverted input for channel 1
TB2	RS-422 output for channel 2
TA2	RS-422 inverted output for channel 2
RB2	RS-422 input for channel 2
RA2	RS-422 inverted input for channel 2
VIN	Supply voltage
GND	Supply return (ground)
VR	Reference voltage (1.65V)
COM	Signal ground (same as GND)

Connection Scenarios

In the following scenarios, only a single channel will be shown. Channel numbers will be replaced by 'n'. For example, 'Rn' would represent the RS-232 receive port for either channel. Note that the associated signal grounds are not shown in the figures, but should be connected to the closest COM pad.

RS-232 ↔ RS-422

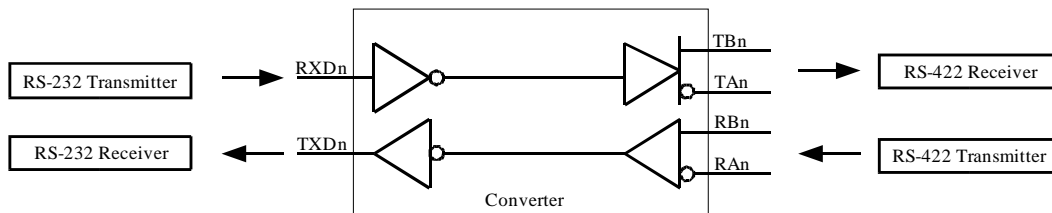

RS-232 ↔ TTL

(the blue jumper is external to the board and must be added by the user)

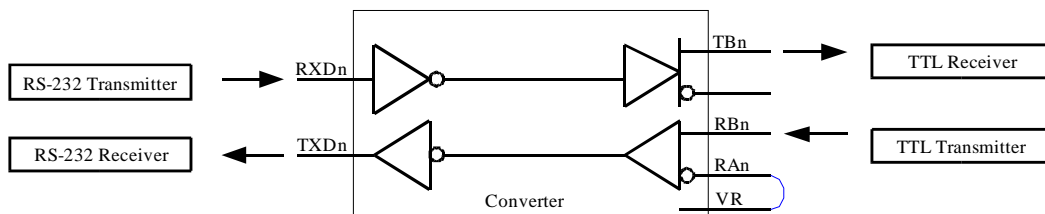



RS-422 ⇔ TTL

The serial converter can convert RS422 to/from TTL for a single serial channel by looping back the RS232 end of the converter as shown below. In this figure, one of the channels is represented as 'n' and the other as 'm'. Jumpers added by the user are shown in blue.

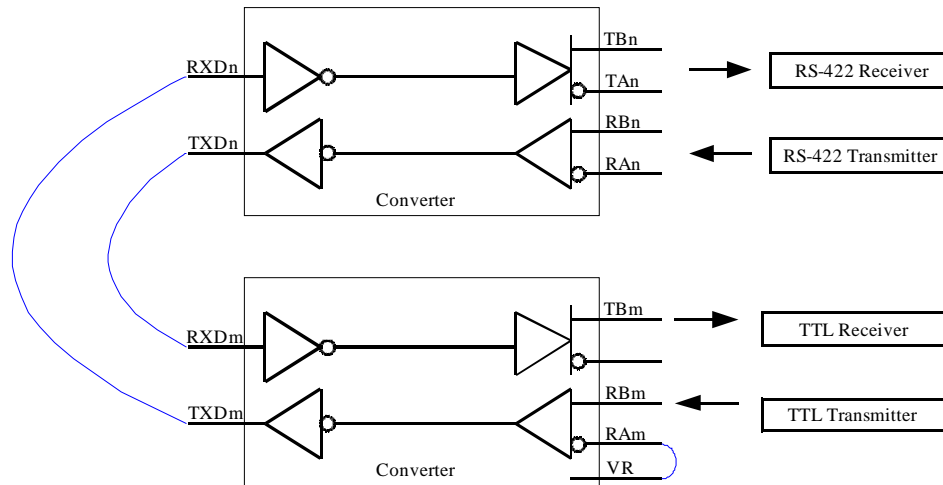

In the case of TTL connections, the serial converter must share a common ground with the TTL device. Also, the on-board reference must be tied to the inverted line of the RS-422 receiver. This allows the receiver to operate correctly with a single TTL input.

Contact

Please direct any questions or comments concerning this document or any of Microbotics' products to support@microboticsinc.com